

Installation and Operational Guide

Please read the manual below for important information on your Viviox product that could prevent damage or serious injury. Failure to follow our instructions and other safety precautions could result in serious injury to you or your passengers, and/or product and vehicle damage.

Important: The installation technician and operator must read this manual before starting installation or operation of your new product. They must have a thorough understanding of automotive systems, electronics and procedures.

WARNING: Please understand that the user and installer assume ultimate, complete and full responsibility in determining proper mounting location and positioning. When installing, consider a location based on its ability to provide total safety to all passengers.

WARNING: DO NOT USE CIRCUIT BREAKERS WITH THIS PRODUCT! All customer-supplied wires that connect with the positive (+) end of the battery must be able to support 125% or more of the maximum operating current. They MUST be fused with the battery to handle the current.

- Before drilling and installation, check both sides of your mounting service.
- Grommets should be installed into all wire passage holes.
- Please read your vehicle's owner's manual; it contains important information about the airbag deployment area. This product should NOT, under any circumstances, be installed in the deployment area of the vehicle's airbag. Do NOT route any wires in this area. Having equipment mounted or located in this area is a serious risk; it could reduce or damage the airbag's effectiveness, or even become a projectile that could result in serious injury or death.
- This device may feature powerful, bright, high-intensity LED lights. DO NOT look at the lights directly, as momentary blindness and/or permanent eye damage can occur.
- DO NOT try to activate or control this product during a hazardous or dangerous driving situation.
- If your device is controlled or activated by a remote, please double check that the control is in a place that will allow for both the control itself, as well as the vehicle, to be used safely in any driving condition and/or situation.

SPECIFICATIONS MODEL: S2300

Dimensions: 7.5" L, 2.75" D, 1.375" H

Input Voltage: 10-30VDC Input Current: 3.0A(MAX)



SPECIFICATIONS MODEL: S4300

Dimensions: 14.75" L, 2.75" D, 1.375" H

Input Voltage: 10-30VDC Input Current: 4.0A(MAX)



SPECIFICATIONS MODEL: S6300

Dimensions: 22.125" L, 2.75" D, 1.375" H

Input Voltage: 10-30VDC Input Current: 6.3A(MAX)



SPECIFICATIONS MODEL: S8300

Dimensions: 29.5" L, 2.75" D, 1.375" H

Input Voltage: 10-30VDC Input Current: 8.4A(MAX)



OPERATION

1. Changing Patterns: Patterns can be changed by momentarily connecting the blue wire to the ground of your vehicle's battery.

Less than a second	Next Pattern
1-3 Seconds	Previous Pattern
3-5 Seconds	Factory Default
5+ Seconds	Turn off and Reset

1. Syncing Instructions: Configure both Dynalights to the same pattern in Phase 1 and connect the yellow wires from each light head together.

2. Alternating Dynalights : Set every other light to the same pattern in Phase 2 and connect the blue wires. To better understand how this feature works, each light head coming from the factory will display Phase 1. In order to have one Dynalight alternate with another, every other light needs to be advanced to the current pattern's Phase 2.

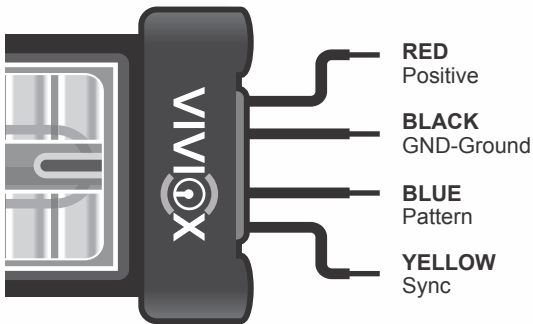

MOUNTING

Surface Mounting

1. Place the unit on the mounting location and position it as desired. Draw a pencil line along the top and bottom of the light and another line between the top and bottom lines.
2. Drill two 1/4" holes anywhere along the middle line. It's best to do this as far apart as possible.
3. Unscrew the end cap and slide the two bolts into the rear of the light. Secure by threading a flat washer and elastic stop nut. Tighten firmly.

Mounting Using Included L Brackets (or optional extended L Brackets)

1. Unscrew the two screws from each end cap.
 2. Place the L brackets on the end caps and use the screws from Step 1 to secure them.
 3. Position the bracket and light onto the mounting location and tighten the brackets firmly.
- Draw two holes for each bracket and use the included screws to mount them securely.

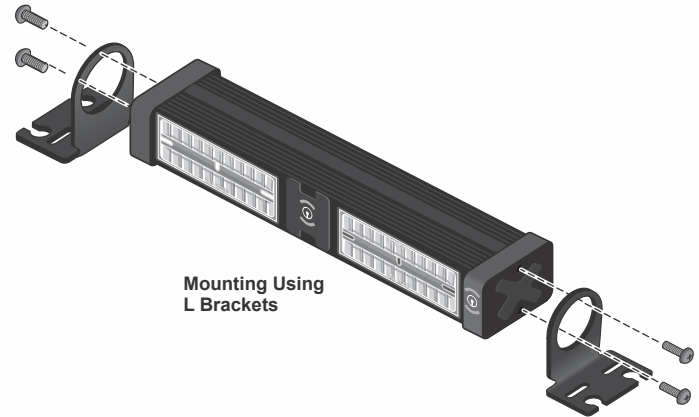

FLASH PATTERNS FOR S4300, S6300, S8300

- 1- Quint Flash Alt --- Factory Default
- 2- Quint Flash In-Out
- 3- Quint Flash Checkerboard
- 4- Quint Flash Sim Phase1
- 5- Quint Flash Sim Phase2
- 6-Quad Flash Alt
- 7- Quad Flash In-Out
- 8- Quad Flash Checkerboard
- 9- Quad Flash Sim P1
- 10- Quad Flash Sim P2
- 11- Single Flash75 Alt
- 12- Single Flash75 In-Out
- 13- Single Flash75 Checkerboard
- 14- Single Flash75 Sim P1
- 15- Single Flash75 Sim P2
- 16- Single Flash375 Alt
- 17- Single Flash375 In-Out
- 18- Single Flash375 Checkerboard
- 19- Single Flash 375 Sim P1
- 20- Single Flash 375 Sim P2
- 21- Modulation Flash Alt
- 22- Modulation Flash In-Out
- 23- Modulation Flash Checkerboard
- 24- Modulation Flash Sim Only
- 25- Quad-Quad Flash Alt
- 26- Single-Double 60
- 27- Single-Double 90
- 28- Single-Double 120
- 29- AUTORUN
- 30- Steady Burn
- 31- Off

FLASH PATTERNS FOR S2300

- 1- Single Alert T-Flash 75FPM alternating (Sync) ---- Default
- 2- Single Alert T-Flash 75FPM simultaneous Phase1 (Sync)
- 3- Single Alert T-Flash 75FPM simultaneous Phase2 (Sync)
- 4- Quad T-Flash 75FPM alternating (Sync)
- 5- Quad T-Flash 75FPM simultaneous Phase1 (Sync)
- 6- Quad T-Flash 75FPM simultaneous Phase2 (Sync)
- 7- Single T-Flash 75FPM alternating (Sync)
- 8- Single T-Flash 75FPM simultaneous Phase1 (Sync)
- 9- Single T-Flash 75FPM simultaneous Phase2 (Sync)
- 10- Single T-Flash 375FPM alternating (Sync)
- 11- Single T-Flash 375FPM simultaneous Phase1 (Sync)
- 12- Single T-Flash 375FPM simultaneous Phase2 (Sync)
- 13- Action Flash alternating
- 14- Action Flash simultaneous
- 15- Module Flash alternating
- 16- Module Flash simultaneous
- 17- Action scan
- 18- Steady with 5 Single and Single POP
- 19- Steady - 5 single
- 20- Steady Burn
- 21- Cycle Flash (Demo mode)-Autorun
- 22- Quad Flash75FPM (NFPA)
- 23- Single Flash 75FPM (CA T13)
- 24- Double Flash 75FPM (CA T13)
- 25- Off