

Installation and Operational Guide

Please read the manual below for important information on your Viviox product that could prevent damage or serious injury. Failure to follow our instructions and other safety precautions could result in serious injury to you or your passengers, and/or product and vehicle damage.

Important: The installation technician and operator must read this manual before starting installation or operation of your new product. They must have a thorough understanding of automotive systems, electronics and procedures.

WARNING: Please understand that the user and installer assume ultimate, complete and full responsibility in determining proper mounting location and positioning. When installing, consider a location based on its ability to provide total safety to all passengers.

WARNING: DO NOT USE CIRCUIT BREAKERS WITH THIS PRODUCT! All customer-supplied wires that connect with the positive (+) end of the battery must be able to support 125% or more of the maximum operating current. They **MUST** be fused with the battery to handle the current.



OPERATION

1. Operation Instructions (see diagram below):
In order to activate your Hellfire, connect the red wire to a 12V post and the black wire to the ground post of the vehicle's battery.

2. Changing Patterns:
Patterns can be changed by momentarily connecting the blue wire to the ground of your vehicle's battery.

Less than a second	Next Pattern
1-3 Seconds	Previous Pattern
3-5 Seconds	Factory Default
5+ Seconds	Turn off and Reset

1. Syncing Instructions: Configure both Hellfire's to the same pattern in Phase 1. Connect each light's yellow wires together.

2. To have your Hellfire's alternate, set every other light to the same pattern in Phase 2. Connect the yellow wires. To better understand how this feature works, each light head coming from the factory will display Phase 1. In order to have one hellfire alternate with another, every other light needs to be advanced to Phase 2 of the current pattern.

To Activate the Steady Burn Feature: Apply power (+12VDC) to the white wire.

- ÿ Before drilling and installation, check both sides of your mounting service.
- ÿ Grommets should be installed into all wire passage holes.
- ÿ Please read your vehicle's owner's manual; it contains important information about the airbag deployment area. This product should NOT, under any circumstances, be installed in the deployment area of the vehicle's airbag. Do NOT route any wires in this area. Having equipment mounted or located in this area is a serious risk; it could reduce or damage the airbag's effectiveness, or even become a projectile that could result in serious injury or death.
- ÿ This device may feature powerful, bright, high-intensity LED lights. DO NOT look at the lights directly, as momentary blindness and/or permanent eye damage can occur.
- ÿ DO NOT try to activate or control this product during a hazardous or dangerous driving situation.
- ÿ If your device is controlled or activated by a remote, please double check that the control is in a place that will allow for both the control itself, as well as the vehicle, to be used safely in any driving condition and/or situation.

FLASH PATTERNS

Patterns for solid colors:

- 1: Single 120 FPM Ph1-Color 1&2
- 2: Single 120 FPM Ph2-Color 1&2
- 3: Single 300 FPM Ph1-Color 1&2
- 4: Single 300 FPM Ph2-Color 1&2
- 5: Single 75 FPM Ph1-Color 1&2
- 6: Single 75 FPM Ph2-Color 1&2
- 7: Double 75 FPM Ph1-Color 1&2
- 8: Double 75 FPM Ph2-Color 1&2
- 9: Double 120 FPM Ph1-Color 1&2
- 10: Double 120 FPM Ph2-Color 1&2
- 11: Quad 75 FPM Ph1-Color 1&2
- 12: Quad 75 FPM Ph2-Color 1&2
- 13: Quad 120 FPM Ph1-Color 1&2
- 14: Quad 120 FPM Ph2-Color 1&2
- 15: Quint 120 FPM Ph1-Color 1&2
- 16: Quint 120 FPM Ph2-Color 1&2
- 17: 2 Double 75 FPM, 4 Quad 120 FPM
- 18: Module Flash Color 1<-->2
- 19: AUTORUN
- 20: STEADY BURN
- 21: OFF

Patterns for split colors:

- 1: Single 120 FPM Ph1-Color 1&2
- 2: Single 120 FPM Ph2-Color 1&2
- 3: Single 120 FPM Ph1-Color 1
- 4: Single 120 FPM Ph2-Color 2
- 5: Single 120 FPM Alt. Color 1<-->2
- 6: Single 300 FPM Ph1-Color 1&2
- 7: Single 300 FPM Ph2-Color 1&2PP7:
Single 300 FPM Ph2-Color 1&2
- 8: Single 300 FPM Ph1-Color 1
- 9: Single 300 FPM Ph2-Color 2
- 10: Single 300 FPM Alt. Color 1<-->2
- 11: Single 75 FPM Ph1-Color 1&2
- 12: Single 75 FPM Ph2-Color 1&2
- 13: Single 75 FPM Alt. Color 1<-->2
- 14: Double 75 FPM Ph1-Color 1&2
- 15: Double 75 FPM Ph2-Color 1&2
- 16: Double 75 FPM Alt. Color 1<-->2
- 17: Double 120 FPM Ph1-Color 1&2
- 18: Double 120 FPM Ph2-Color 1&2
- 19: Double 120 FPM Alt. Color 1<-->2
- 20: Quad 75 FPM Ph1-Color 1&2
- 21: Quad 75 FPM Ph2-Color 1&2
- 22: Quad 75 FPM Ph1-Color 1
- 23: Quad 75 FPM Ph2-Color 2
- 24: Quad 75 FPM Alt. Color 1<-->2
- 25: Quad 120 FPM Ph1-Color 1&2
- 26: Quad 120 FPM Ph2-Color 1&2
- 27: Quad 120 FPM Ph1-Color 1
- 28: Quad 120 FPM Ph2-Color 2
- 29: Quad 120 FPM Alt. Color 1<-->2
- 30: Quint 120 FPM Ph1-Color 1&2
- 31: Quint 120 FPM Ph2-Color 1&2
- 32: Quint 120 FPM Alt. Color 1<-->2
- 33: 2 Double 75 FPM, 4 Quad 120 FPM
- P34: Module Flash Color 1<-->2
- P35: AUTORUN
- P36: STEADY BURN
- P37: OFF

MOUNTING

Surface Mounting (See Figure 1.)

1. Position the light unit with the flange attached on the mounting surface and mark the position of the two screws and a center wire passage hole.
2. Drill two holes for the screws and 0.5" center wire passage hole.
3. Place the light unit on the mounting surface and secure it with the included hardware.

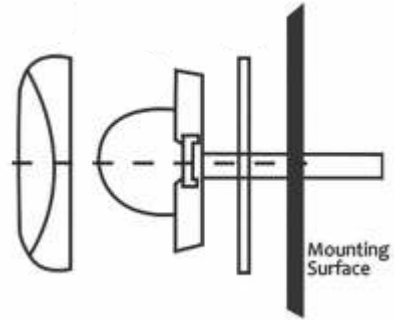

Figure 1.

Headlight or Tail Light Mounting (See Figure 2.)

1. Refer to your vehicle's manual for instructions on how to remove the headlight or taillight assembly.
2. Select the mounting location and choose a surface in the bottom or rear of the light assembly as close to the focal point as possible. Be sure that it doesn't interfere with the operation of the light.
3. Use a saw to cut a 1" hole in the chosen location. Insert the light unit into the hole and mark the location of the two screw sockets. Remove the light and drill the two holes.
4. Place the gasket on the light and insert it in the hole. Use metal screws to secure it to the light assembly.
5. Reinstall the headlight or taillight assembly and route the wires to their appropriate control switches.

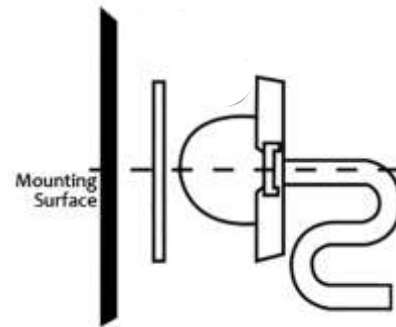

Figure 2.

SPECIFICATIONS

Dimensions in Inches: 0.99" H, 1" D

Input Voltage: 10-30VDC Input Current: 2.5A (MAX)

Optional Brackets

